

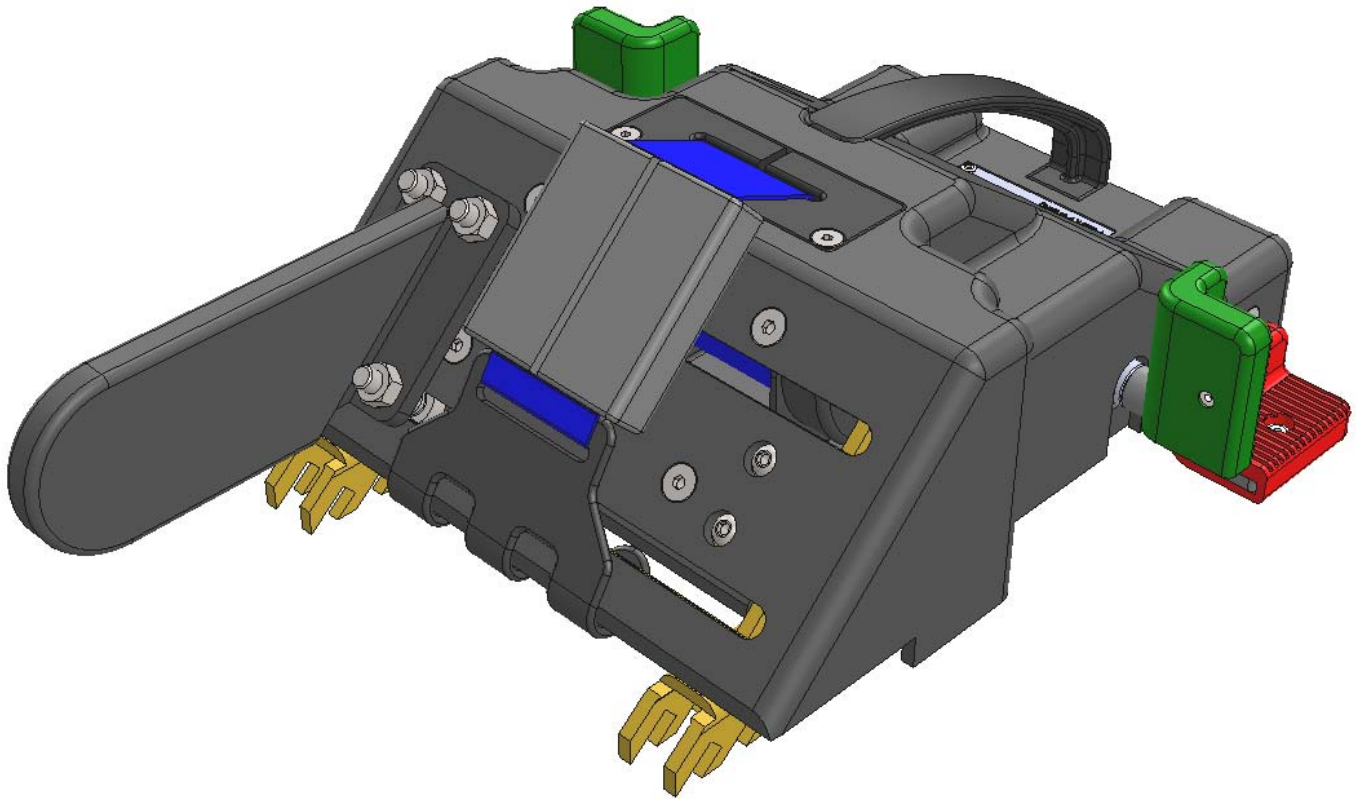

Vehicle Restraint System Field Repair Manual



November 2011
Revision A

**The information contained within this document is the sole property of Holland L.P. and is unauthorized for reproduction without expressed, written permission. If you have received this document in error, please return to:
Holland L.P.
1000 Holland Drive
Crete, IL 60417**

Table of Contents

Retractor Replacement, Part No. 74345	2
Left Pedal Replacement, Part No. 74347	5
Right Pedal Replacement, Part No. 74348	7
Top Cover Replacement, Part No. 74350	9
Tire Grip Replacement, Part No. 74353	13

Required Tools

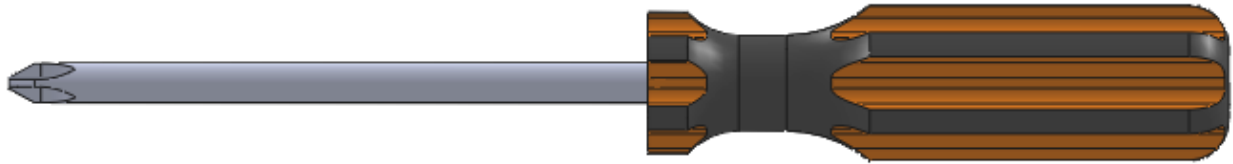

Phillips screwdriver



13mm Combination wrench



3mm Allen wrench



4mm Allen wrench



5mm Allen wrench

Retractor Replacement

Part No. 74345

Retractor Kit Bill of Material

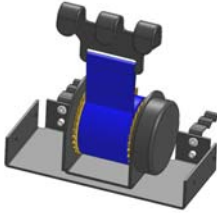
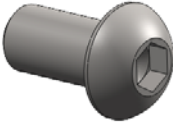
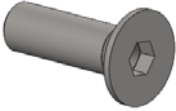
Description	Quantity	
Retractor assembly, Part No. 7052-10	1	
M6 X 0.8-12 Button head screw	8	
M6 X 0.8-20 SOC Flat head screw	2	

Repair Conditions



- Any part of the strap is torn
- Hook becomes severely deformed
- Retractor locks up and will no longer retract or extend
- Plastic coating on hook is peeling off

Retractor Replacement Disassembly

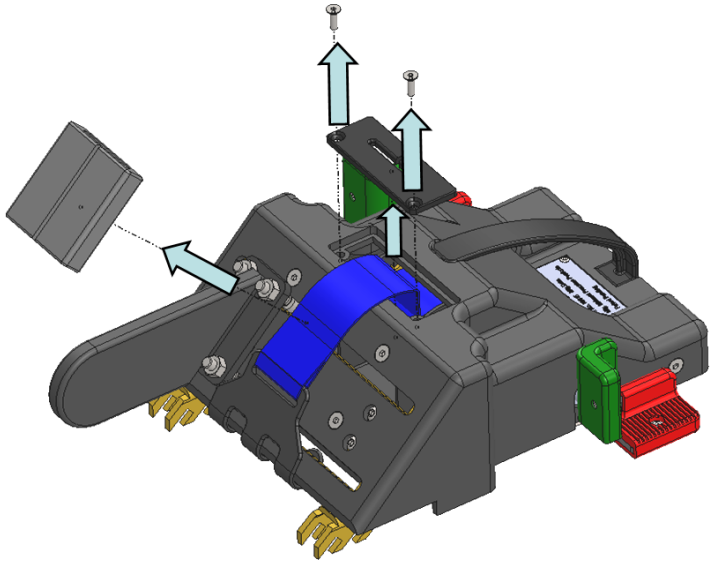
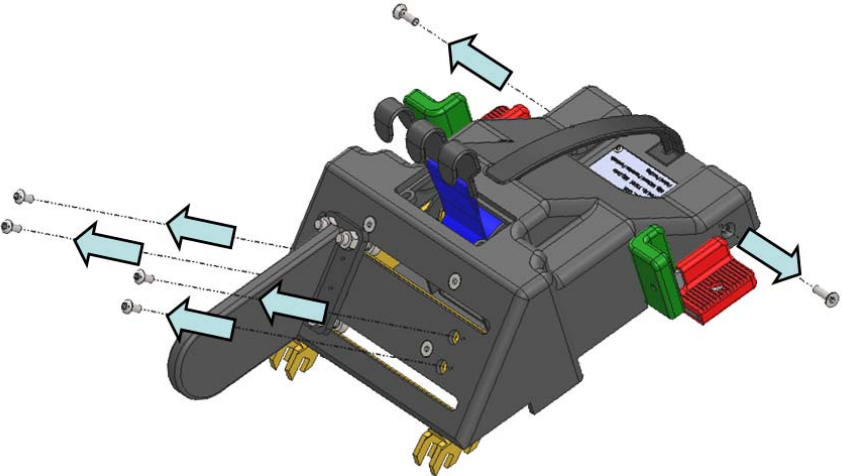
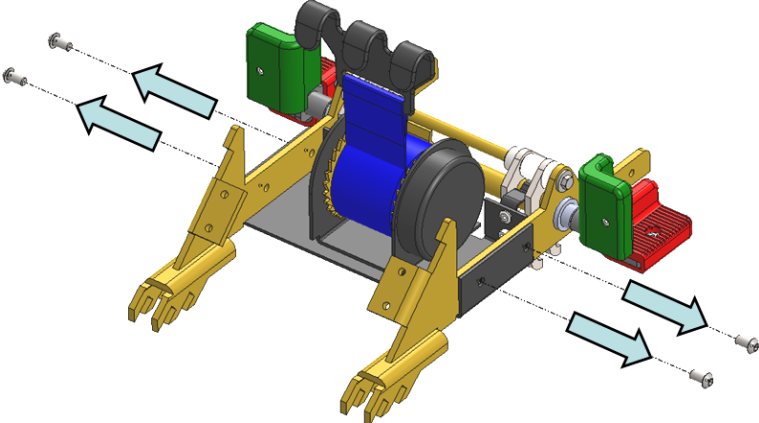
<p>1.</p>		<ul style="list-style-type: none">▪ Remove screws, belt filler cover, and tire grip.
<p>2.</p>		<ul style="list-style-type: none">▪ Remove side screws and ramp face button head screws.▪ Remove top cover and bottom cover.
<p>3.</p>		<ul style="list-style-type: none">▪ Remove retractor screws and take out damaged retractor assembly.

Retractor Replacement Reassembly

4.

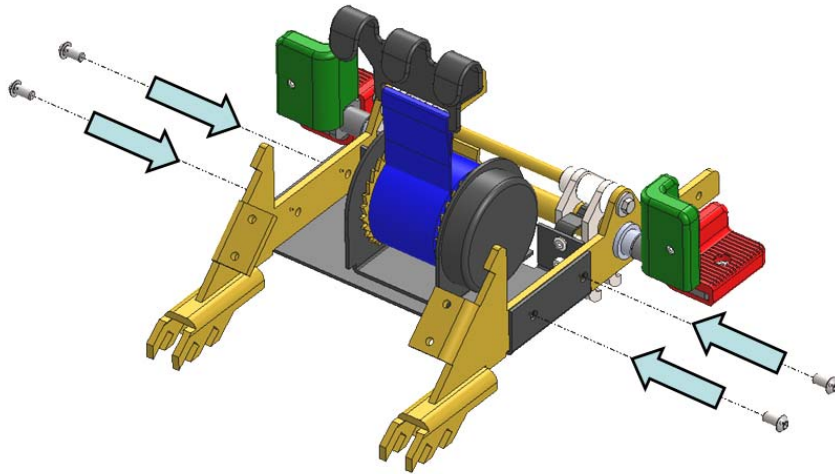

- Insert new retractor.
- Attach button head screws.

5.

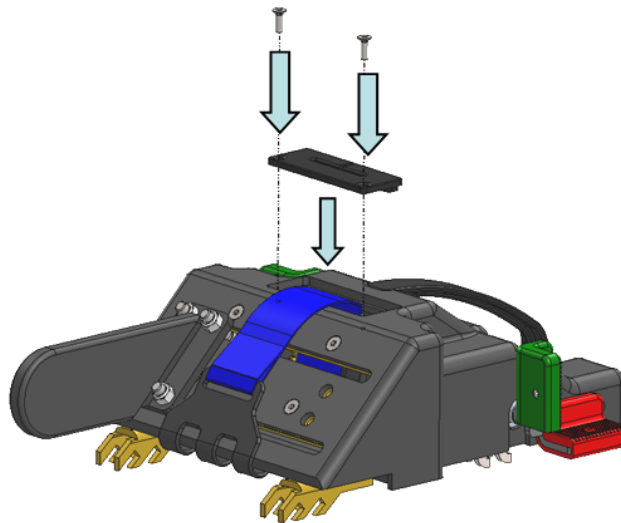

- Attach belt filler cover and screws.
- Insert bottom cover so that the front end slides under the front teeth.

6.

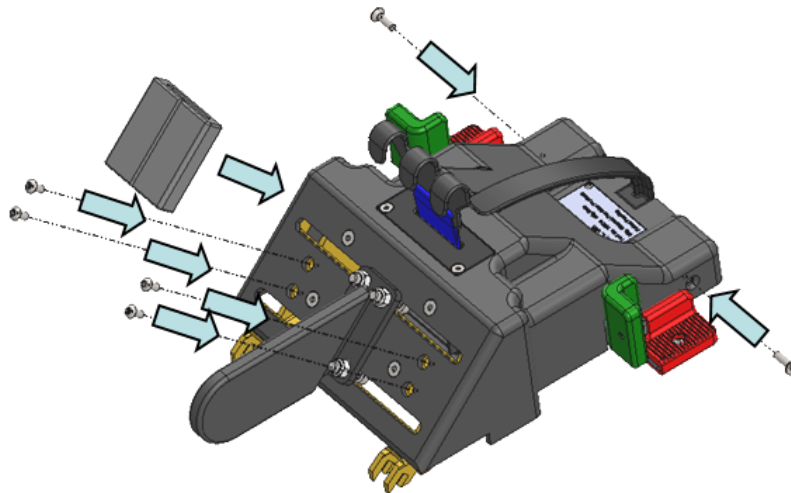



- Attach tire grip.
- Make sure tire grip tabs are resting against ramp and slit end is facing towards you.
- Attach ramp face button head screws and side screws.

Left Pedal Replacement

Part No. 74347

Left Pedal Kit Bill of Material

Description	Quantity	
Left pedal assembly <ul style="list-style-type: none"> ▪ Lock pedal, Part No. 7052-16 (Qty: 1) ▪ Pedal cover red, Part No. 7052-28-LH (Qty: 1) ▪ Pedal cover green, Part No. 7052-29-LH (Qty: 1) ▪ 3/16 X 1/2 Pop rivet (Qty: 2) 	1	
M5 X 0.8-12 Button head screw	1	
M5 Flat washer	1	

Repair Conditions



- Rubber pedal becomes torn
- Metal lock pedal becomes severely deformed
- Pedal detaches
- Pedal is missing

Left Pedal Replacement Disassembly

1

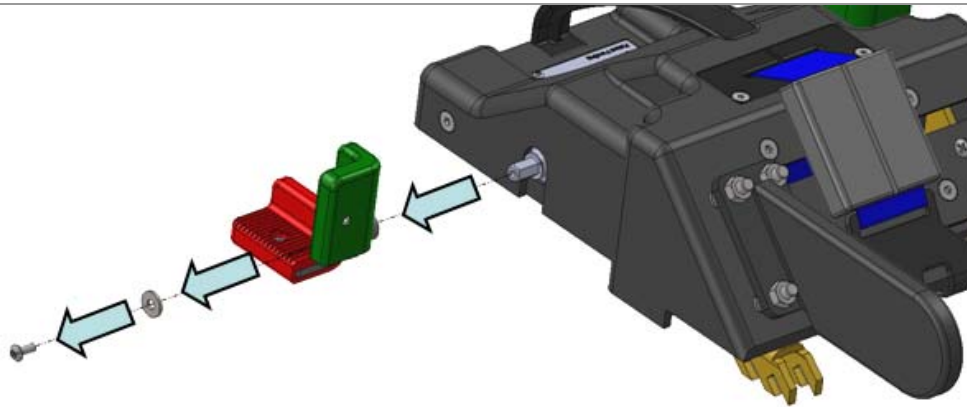

- Remove screw and washer.
- Then remove damaged left pedal.

Left Pedal Replacement Reassembly

2

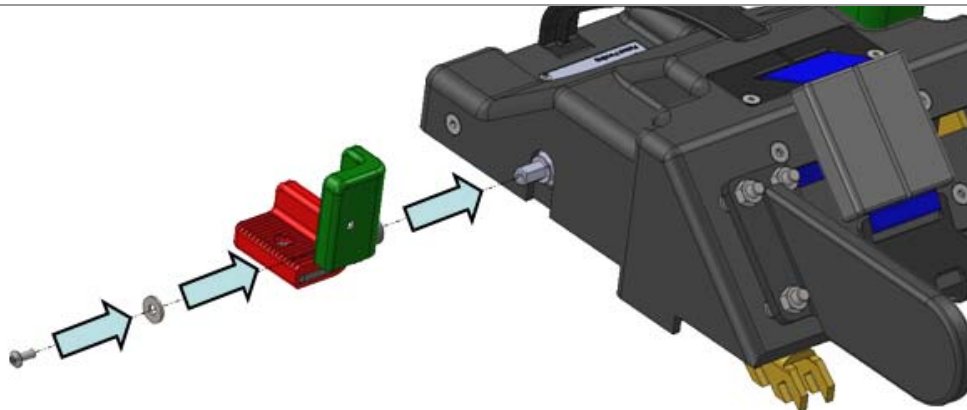



- Attach new left pedal.
- Then attach washer and screw.

Right Pedal Replacement

Part No. 74348

Right Pedal Kit Bill of Material

Description	Quantity	
Right pedal assembly <ul style="list-style-type: none"> ▪ Lock pedal, Part No. 7052-16 (Qty: 1) ▪ Pedal cover red, Part No. 7052-28-RH (Qty: 1) ▪ Pedal cover green, Part No. 7052-29-RH (Qty: 1) ▪ 3/16 X 1/2 Pop rivet (Qty: 2) 	1	
M5 X 0.8-12 Button head screw	1	
M5 Flat washer	1	

Repair Conditions



- Rubber pedal becomes torn
- Metal lock pedal becomes severely deformed
- Pedal detaches
- Pedal is missing

Right Pedal Replacement Disassembly

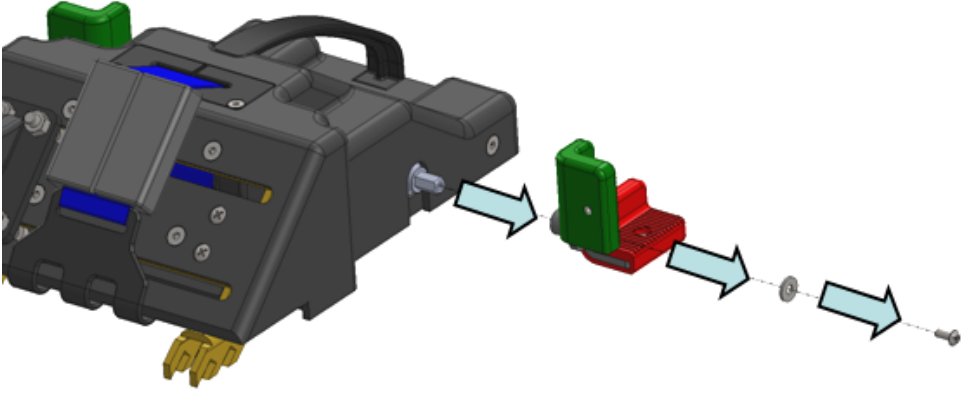
1.		<ul style="list-style-type: none">▪ Remove screw and washer.▪ Then remove damaged right pedal.
-----------	--	---



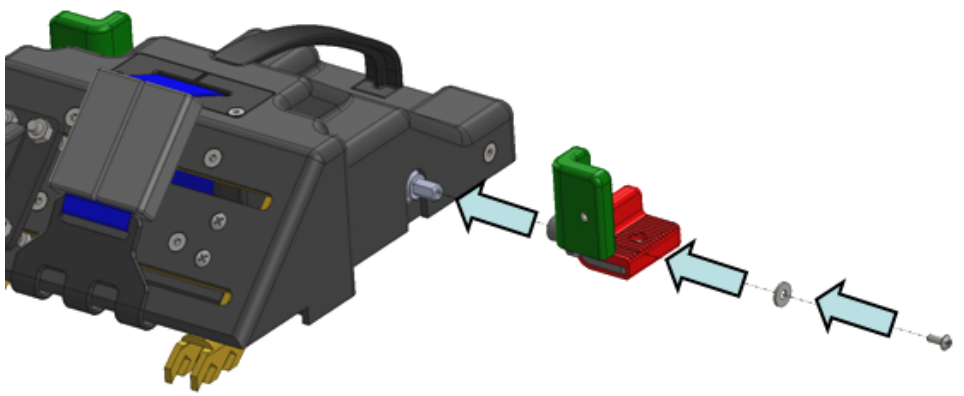



Right Pedal Replacement Reassembly

2.		<ul style="list-style-type: none">▪ Attach new right pedal.▪ Then attach washer and screw.
-----------	---	---

Top Cover Replacement Kit

Part No. 74350

Top Cover Kit Bill of Material

Description	Quantity	
Top cover <ul style="list-style-type: none"> ▪ Top cover with handle, Part No. 7052-7 (Qty: 1) ▪ Blank mfg. label, Part No. 7052-60a (Qty: 1) ▪ 1/8 X 0.425 Aluminum pop rivet (Qty: 2) 	1	
M6 X 0.8-20 Flat head screw	6	
7052-24 Belt filler cover	1	
M5 X 0.8-16 Flat head screw	2	
M8 X 1.25 Hex lock nut	4	
M6 X 0.8-12 Button head screw	4	

Repair Conditions



- Large cracks
- Handle gone
- Regions of cover broken off

Top Cover Replacement Disassembly

1.

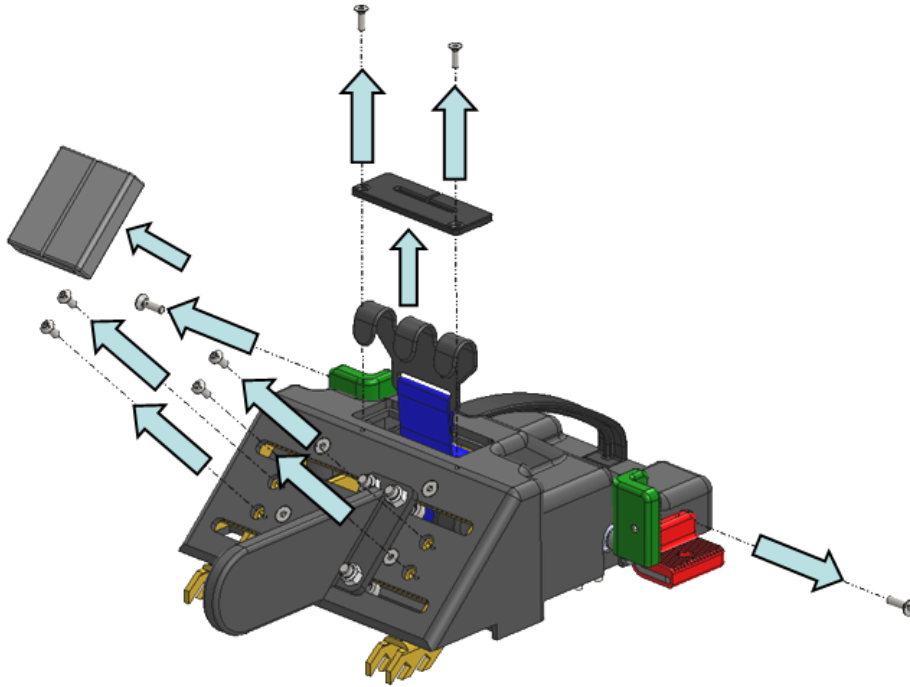

- Remove belt filler cover screws, belt filler cover, tire grip, side screws, and the four ramp face button head screws.

2.

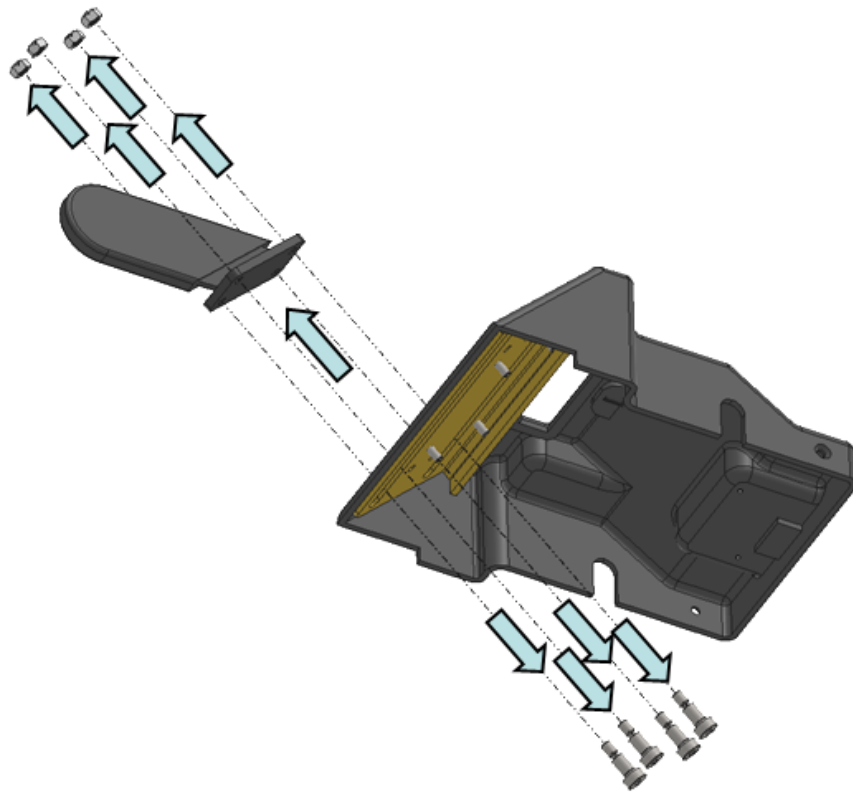

- Remove shoulder screws, nuts, and lateral restraint.

3.

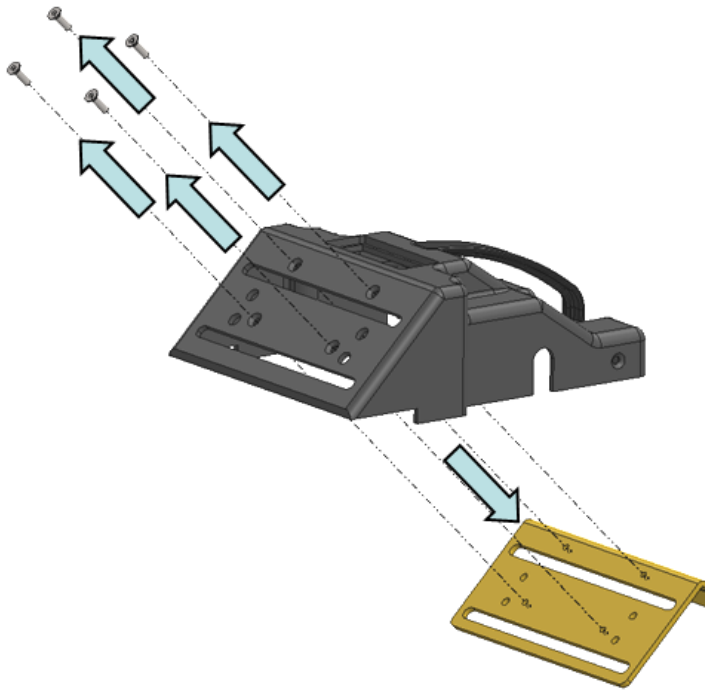

- Remove remaining four flat head screws.
- Then remove metal backing plate.

Retractor Replacement Reassembly

4.

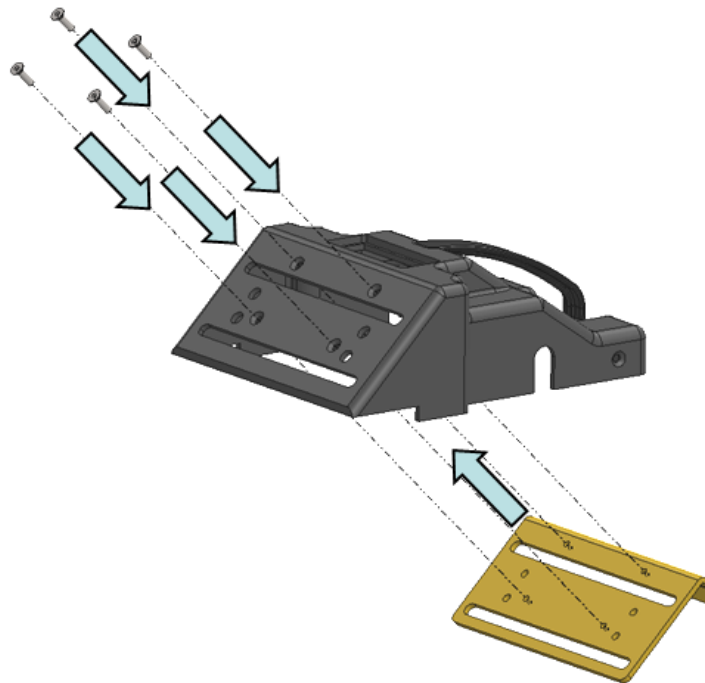

- Reattach backing plate to new top cover with the four flat head screws.

5.

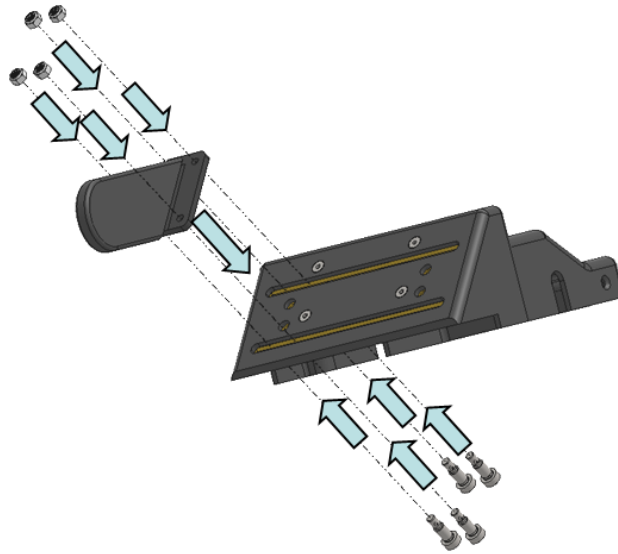

- Reattach lateral restraint using shoulder screws and nuts.

6.

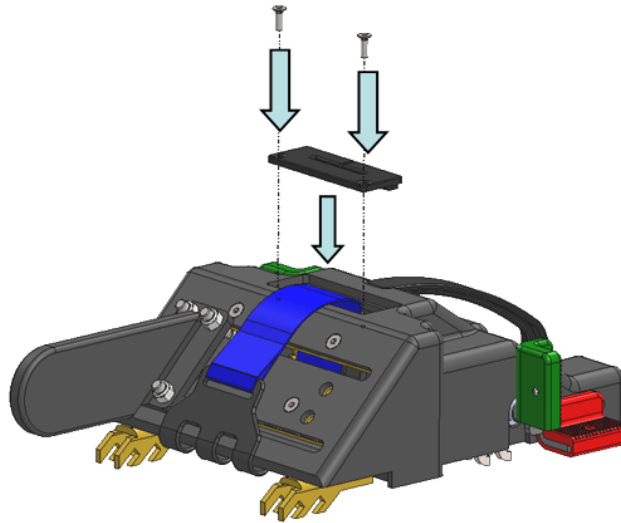

- Attach belt filler cover and screws.
- Insert bottom cover so that the front end slides under the front teeth.

7.

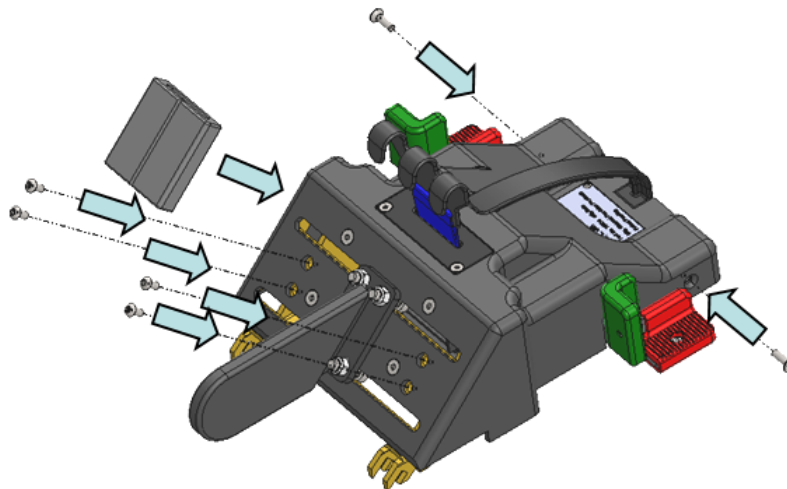

- Attach tire grip.
- Make sure tire grip tabs are resting against ramp and slit end is facing towards you.
- Attach ramp face button head screws and side screws.

Tire Grip Replacement

Part No. 74353

Tire Grip Bill of Material

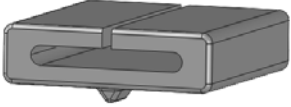
Description	Quantity	
Tire Grip, Part No. 7052-70	1	

Repair Conditions

- Ripped
- Missing

Tire Grip Replacement Disassembly

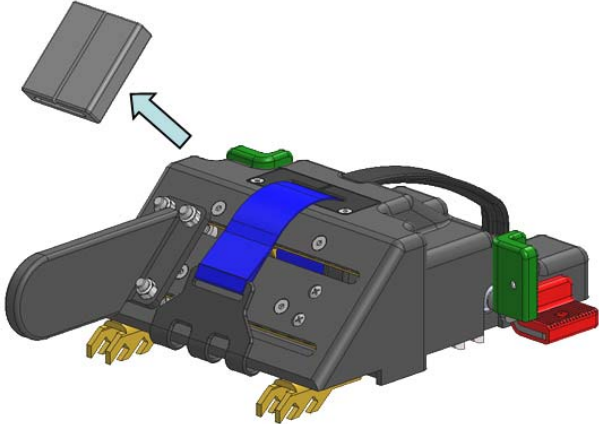
<p>1.</p>		<ul style="list-style-type: none">Remove damaged tire grip.
-----------	--	---

Tire Grip Replacement Reassembly

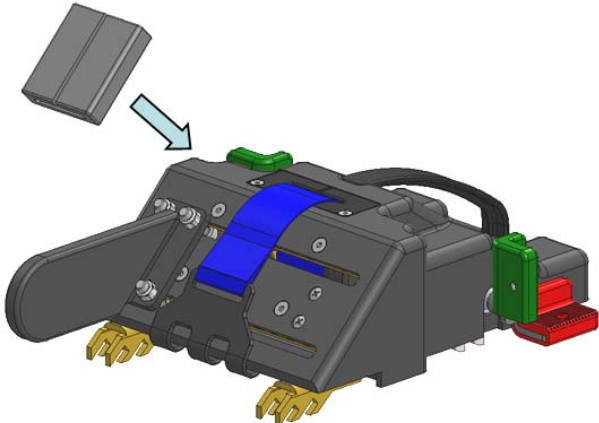
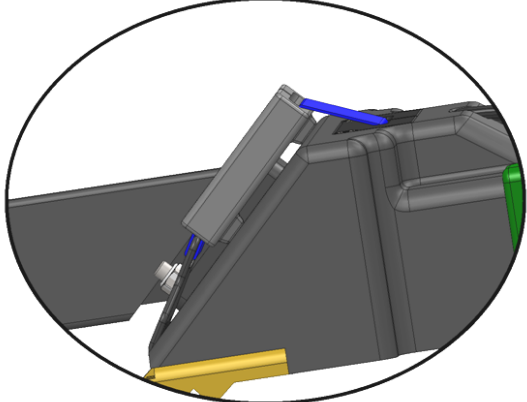
<p>2.</p>		<ul style="list-style-type: none">Attach new tire grip.
<p>3.</p>		<ul style="list-style-type: none">Make sure tire grip tabs are facing against the ramp face.